

Easy Fit Pipe Entry Fittings

With flexible boots and donuts

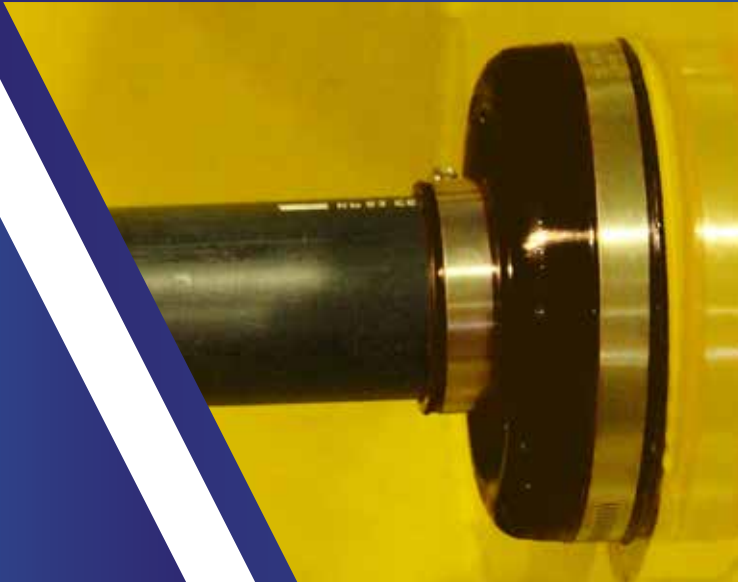

- One man installation
- One single hole to drill
- Installed in concrete, PE and GRP sump walls
- Boots to seal all pipe brands and diameters, including corrugated secondary ducts
- Compatible with all fuel types, ethanol blends up to E85 and biodiesel
- Double-sided pipe sealing possible
- Pipe entry angles up to 12 degrees

The logo for CGH Belgium features a stylized circular graphic composed of two overlapping loops, one blue and one yellow, positioned to the left of the text. The text 'CGH' is in a large, bold, black sans-serif font, and 'Belgium' is in a smaller, italicized, black sans-serif font below it.

CGH
Belgium

Fittings for all pipe brands and sizes

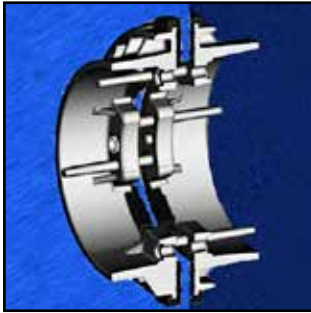

Easy Fit pipe fittings require only one hole to be drilled in the sump wall, no bolt holes.

Each Easy Fit cuff comes with a Protex gasket, snapped onto the body flange. The cuff installed outside is fitted with hex nuts. For easy, one-man installation, the cuffs are fitted with alignment pins. The two cuffs are held together with bolts, tightened from the inside to max 60 inch lbs or 0,7 kgm with an Allen key.

Easy Fit cuffs: dimensions and components

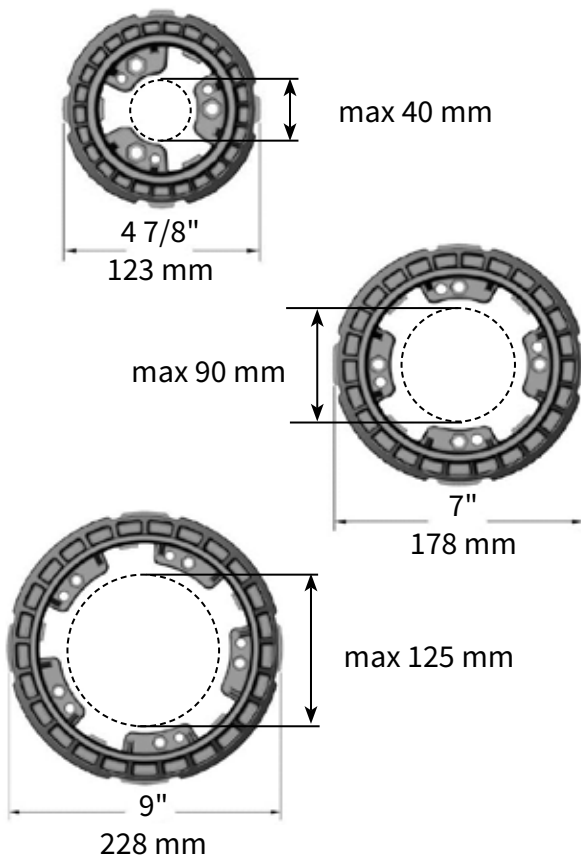

TEF0035	“Easy Fit” cuff body, small
	For pipes up to 40 mm O.D.
	2x small cuff bodies
	2x flat clip-on gaskets
	3x stainless allen bolts + embedded nuts

TEF0055	“Easy Fit” cuff body, medium
	For pipes from 50 up to 90 mm O.D. or secondary duct up to 117 mm O.D.
	2x medium cuff bodies
	2x flat clip-on gaskets
	4x stainless allen bolts + embedded nuts

TEF0075	“Easy Fit” cuff body, large
	For pipes from 90 up to 125 mm O.D. or secondary duct up to 145 mm O.D.
	2x large cuff bodies
	2x flat clip-on gaskets
	5x stainless allen bolts + embedded nuts

Tools: Hole saw and Allen key



Tools for	Code	Description
TEF0035	HS3125	Hole saw 3 1/8" - 80 mm
TEF0055	HS5018	Hole saw 5 1/8" - 130 mm
TEF0075	HS6058	Hole saw 6 5/8" - 168 mm
Bolts	ACB034	Allen key 3/16, with handle

ProTex flexible sealing boots

Boots for TEF0035 small size "Easy Fit" pipe entry fitting	
TRP3522	For pipes with O.D. 22 mm = TRP3535 + TRI3522 reducing donut
TRP3525	For pipes with O.D. 25 mm = TRP3535 + TRI3525 reducing donut
TRP3532	For pipes with O.D. 32 mm = TRP3540 + TRI4032 reducing donut
TRP3535	For pipes with O.D. 35 mm
TRP3540	For pipes with O.D. 40 mm
TRPC35	Cap to plug off the TEF0035 entry fitting



Boots for TEF0055 medium size "Easy Fit" pipe entry fitting	
TRP5550	For pipes with O.D. 50 mm
TRP5563	For pipes with O.D. 63 mm
TRP5575	For pipes with O.D. 75 mm
TR5584	For corrugated duct O.D. 90 mm and TD390x or CE390x donuts for pipe / cable
TRP5590	For pipes with O.D. 90 mm
TRPD90	Sealing ring for SP3501 3.5" secondary duct
TRP5596(A)	For TD390x pipe or CE390x cable donuts. TRP5596A = with air test valve
TRP55117(S)	For SP4501 4.5" secondary duct, nylon clamps. _S = stainless steel clamps
TRPD117	Sealing ring for 4.5" secondary duct (SP4501)
TRPC55	Cap to plug off the TEF0055 entry fitting

Boots for TEF0075 large size "Easy Fit" pipe entry fitting	
TRP7590	For pipes with O.D. 90 mm
TRP75110(A)	For pipes with O.D. 110 mm or TD490x donuts. TRP75110A = with air test valve
TRP75125	For pipes with O.D. 125 mm
TRP75145(S)	For 6" secondary duct (SP6001), nylon clamps. _S = stainless steel clamps
TRPD145	Sealing ring for 6" secondary duct (SP6001)
TRPC75	Cap to plug off the TEF0075 entry fitting

Donuts for Fogs piping and electric cables

Donut	Fogs piping	Inserts	Reduction
TD3900	1" + 2 x 3/4"	CS1050	1" to 1/2"
		CS0575	3/4" to 1/2"
TD3902	1 x 1 1/4" + 2 x 3/4"	CS0575	3/4" to 1/2"
TD4900	4 x 1"	CS1075	1" to 3/4"
TD4902	3 x 1 1/4"	CS1210	1 1/4" to 1"
		CS1275	1 1/4" to 3/4"

Donut	Material, cable size or cable gland thread
CE3900	NBR, 6 x 14 + 5 x 19 mm
CE3901.50	Alu, 5 x M20
CE3901.52	Alu, 3 x M20 + 2 x M25



Donuts for other types of piping may be available. Contact us for more information.

Easy Fit entry fittings



Pipe entry fittings

Product description

Entry fitting functions:

To prevent the stored fluids from leaking out of the tank sump or ground water from entering, leaktight pipe entry fittings must be used. Pipe entry fittings are composed of two parts:

- A cuff body installed into the tank sump wall.
- A flexible boot to seal the entering pipe, by default installed on the inside cuff, and if double sealing is required, a second boot is installed on the the outside cuff.

Cuff body properties:

- Manufactured in Zytel, offering long term mechanical integrity and that is compatible with all fuels, ethanol mixtures up to E85 and biodiesel.
- Can be installed into PE, GRP, steel or concrete chamber walls.
- Independent of the thickness of the access chamber wall.
- Requires only one hole to be drilled in the chamber wall, no bolt holes needed.
- Equipped with large inside and outside sealing gaskets, in Protex non-urethane copolymer.
- Provides an inside and an outside cuff in case double sealing of the pipe is required.
- Cuff body tightening is done from the inside of the chamber, with stainless steel bolts and nuts.

Flexible boot properties:

- The boots can seal all types of pipe (PE, steel, corrugated ducts) and pipe diameters commonly used in service station construction.
- Manufactured in ProTex non-urethane copolymer that offers:
 - Long term flexibility and mechanical integrity.
 - Compatibility with all fuels, ethanol mixtures up to E85 and biodiesel.
 - Resistance to UV rays and ozone.
- The material carries a third-party approval (UL Listing or equivalent).
- The boot provides enough flexibility for pipe entry angles of up to 12 degrees.
- Stainless steel clamps are used for boots installed inside the access chamber.
- Nylon clamps can be used for boots installed on the outside cuff.
- Available with an air test valve when required for a double wall pipe system.



CGH Belgium nv
Rijksweg 10 C
B- 2880 BORNEM
Tel.: +32 (0)3 459 80 76
E-mail: info@cghbelgium.com

www.cghbelgium.com

Easy Fit - EN - 20180321
Non-contractual document